

SHEET-METAL EXPANDING MACHINE, WITH OSCILLATORY MAIN MOTION

Romeo CIOARĂ*, Andrei CREȚUL**

*“Transilvania” University of Brasov, Romania

** S.C. LOIRE ETUDE UTILAJ DE PRESA S.R.L., Braşov, Romania

Abstract. The cinematic diagram of principle a machine-tool, particularly of a sheet-metal expanding machine allows the highlighting of mechanisms and structural elements the replacement or constructive optimisation of which represents an important means of innovation. Identical cinematic diagrams of principle can correspond to different solutions for the same type of machine, or even for different types of machines.

In machines manufacturing, rotating, and in particular oscillatory motion is often easier generated and more favourable than linear motion. Hence it is preferable to design the working process as often as possible such as to include a rotating or oscillatory main motion and as many as possible of the other working and auxiliary motions.

The paper proves the possibility of redesigning a sheet-metal expanding machine by replacing the linear alternating main motion by a self-returning oscillation, and by carrying out the corresponding required constructive modifications. While the cinematic complexity of the machine remains unchanged, the constructive and technological benefits are evident.

Keywords: sheet metal expanding machines, oscillatory motion, cinematic structures, invention

1. Introduction

Worldwide evolution shows the continuous growth of the weight held by industrial production achieved by various cold forming methods. Expanded sheet-metals also follow this tendency. These are used as finite parts, but especially as semi-products, generally being further processed by drawing or bending.

Expanded sheet-metals, examples in figure 1, have the general workability advantages of sheet-metals, and also some specific advantages: reduced material consumption (even exceeding 50%), low specific weight, and good stiffness. Expanded sheet-metals are frequently used in electrical and automotive industries, in mining, in machines manufacturing industry, in food and general goods industries, etc. Expanded sheet-metals are currently used as protection fences,

separation walls, protection masks, anti-skidding surfaces, and even decorative elements. [6] New fields of use for expanded sheet-metals are possible, and research in this respect is ongoing.

Sheet-metal expanding machines form a specialized subclass of machine-tools for cold forming. Such machines are relatively rare, produced in small series and therefore research demand is not significant in this field. The few sheet-metal expanding machine manufacturers promote modernizations, improvements or new constructive solutions to a certain degree, which however do not include changes of the working principle.

The main geometrical characteristics of expanded sheet metals are identified in figure 2. We identify the thickness g of the semi-product sheet, the pitch p_1 of the expanded sheet metal, the

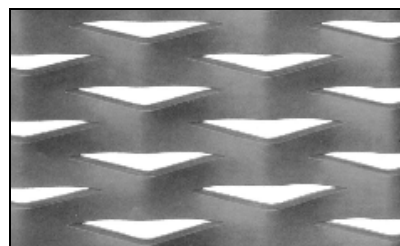
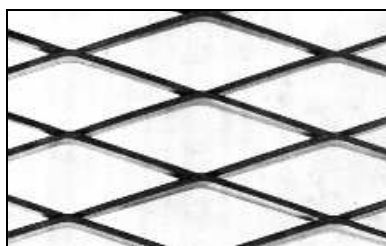
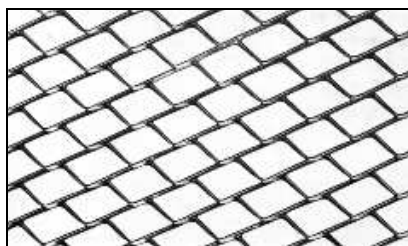

Figures 1 (a, b, c). Examples of expanded metal sheets

pitch p_2 of the semi-product feed. In relation to the mesh of the expanded sheet, we identify the angle 2α of the mesh profile, (in the case of sheets with unsymmetrical meshes, the angle is $\alpha + \beta$), the bridge f and the longitudinal pitch p_{te} . B is the width of the sheet.

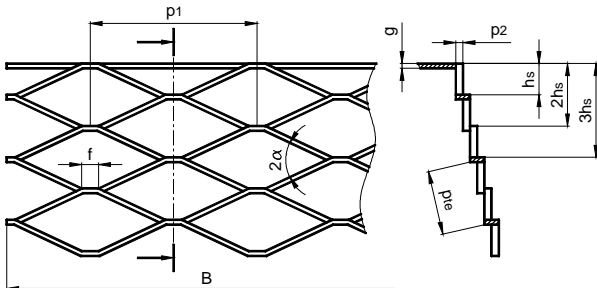

Figure 2. The main geometrical characteristics of expanded metal sheets

The mesh profile of the expanded metal sheet is obtained by copying the profile of the mobile cutter of the machine. The profile of the mobile cutter is taller than the profile transposed on the expanded sheet, that is slightly taller than the length h_s of the effective stroke of the mobile cutter.

The following relations can be written to link the characteristic dimensions of an expanded sheet metal:

$$p_1 = 2f + \frac{h_s}{\sin \alpha} + \frac{h_s}{\sin \beta}, \quad (1)$$

$$p_{te} = 2 \cdot \sqrt{h_s^2 + p_2^2}. \quad (2)$$

To a length l_t of the semi-product corresponds a length l_{te} of the expanded sheet, calculated with the relation:

$$l_{te} = l_t \cdot \sqrt{\left(\frac{h_s}{p_2}\right)^2 + 1}. \quad (3)$$

2. The expanding process

The main motion of current expanding machines is alternating linear in a vertical plane, carried out by a sliding block, obtained by transforming the continuous rotation of a main shaft by means of a crank- connecting rod - sliding block mechanism. Because in most cases the sliding block is long, for its good drive, two identical crank – connecting rod – sliding block mechanisms are used, and implicitly a main shaft with two cranks .

On this sliding-block the mobile part of the tool is fixed – a long cutter, the active front face

(the rake) of which is profiled as a rack. Its profile is identical with the profile of the machined expanded sheet metal, figure 3. The action of the tool on the semi-product generates a number of indentations and local bends of the sheet material in front of the mobile cutter.

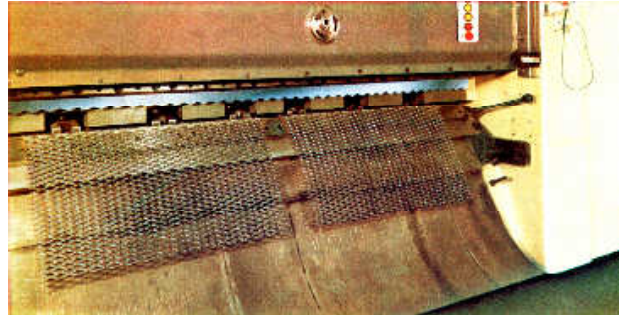

Figure 3. The working area and the mobile cutter of a sheet metal expanding machine

In the proximity of every superior dead point of the sliding block double stroke, a certain discrete linear motion is necessary, – every time in alternating directions – along the direction of the rack of the mobile cutter, by half the pitch p_1 of its profile. A complete mesh row of the expanded sheet is obtained after two double strokes of the sliding-block.

In the interval between two effective strokes the feed of the semi-product sheet must be of pitch p_2 . For this a tongs device carries out the clamping of the sheet, its feed by pitch p_2 , the release of the sheet and withdrawal to the initial position. The two groups of motions are perpendicular.

In interval between the two feed motions of the semi-product sheet, this must be fixed on the machine-tool. For this purpose cross bar is used, which in a vertical plane carries out a descending motion (fixing) and a lifting motion (release). To expand sheets with a different profile, the mobile tool must be replaced by one with an adequate profile, and the length and position of the mobile tool (hence of the sliding block) must be adjusted.

All these requirements of a sheet metal expanding machine are reflected in the cinematic diagram of principle [5] of figure 4, in which:

M – electric motor, with the rated speed n_M ;

i_c – transmission ratio of the belt mechanism;

V – flywheel, with the rated speed n_V ;

C – clutch;

F – brake;

ACFm – monobloc clutch-brake unit;

R – reduction gear, with reduction ratio i_R ;

AP – main shaft, with rated speed n_{AP} (motion II);

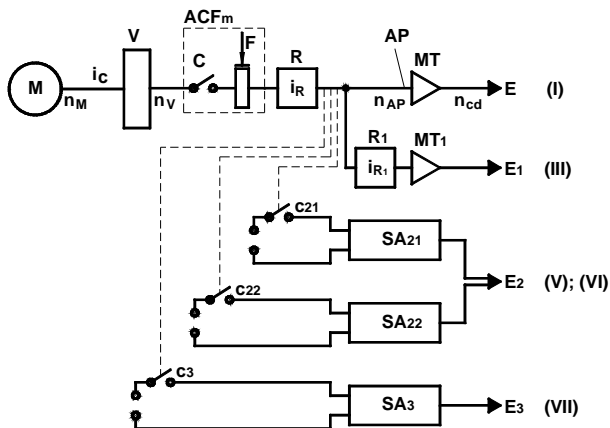

Figure 4. Cinematic diagram of principle of a sheet metal expanding machine

MT – transforming mechanism for generating the main motion (crank mechanism of current machines);

n_{cd} – frequency of the main motion ($n_{cd} = n_{AP}$);

E – executing element of the main motion (motion I) (E is in fact the sliding block of the machine, on which the mobile tool is fixed);

E_1 – executing element of the discrete left-right linear motion by pitch p_1 (motion III) (E_1 is the sliding block of the machine as well);

R_1 – reduction gear, with ratio i_{R1} . It is necessary if the frequency of motion III is different from the frequency of motion I;

MT_1 – transforming mechanism to obtain motion III;

E_2 – executing element that carries out the motions necessary for the feed of the semi-product sheet: motion V (feed by pitch p_2 – withdrawal) and VI (clamping – release). The active direction of motion V determines the feed motion of sheet IV;

SA_{21} – actuating system generating motion V;

SA_{22} – actuating system generating motion VI;

SA_3 – actuating system generating motion VII;

Note: The SA can be mechanical, hydraulic, pneumatic, electro-mechanical or electro-magnetic.

c_{21} , c_{22} , c_3 – coupling elements for driving SA_{21} , SA_{22} , SA_3 .

c_{21} , c_{22} , c_3 are controlled by the main shaft of the machine.

3. Expanding machine with oscillatory main motion

In most cases, in machines manufacturing industry, and not only, rotation motion is more favourable – constructively and technologically speaking – than linear motion. As a particular case, the oscillatory motion has similar attributes

compared to linear motion, its advantages being evident, concerning the simplicity of guiding, the construction of the transforming mechanisms and the dynamic characteristics.

These aspects being emphasized and considering the authors' previous concerns [2, 3] with the kinematics and construction of sheet metal expanding machines, the initiation of studies oriented towards innovating-inventing aiming at the development of new cinematic and constructive solutions for this type of machine was a natural consequence, partially triggered subconsciously [4]. The essential question that was asked was „what has to be done (at the level of the cinematic diagram of principle, in the first place!!) and which are the cinematic and constructive consequences of a sheet metal expanding machine, the main motion of which is a self-returning oscillatory motion?“.

Analyzing the diagram of principle of figure 4 it can be observed that it corresponds completely also to a sheet metal expanding machine with an oscillatory main motion: MT is no longer a crank mechanism, but one that transforms the rotation motion into a self-returning oscillatory motion, like, for example, the four-bar mechanism, the oscillatory crank guide or the cam gear mechanism with oscillatory pusher. The change of the type of transforming mechanism in order to obtain the main motion will most probably determine the change of the type and construction of the MT_1 transforming mechanism, the one that ensures the obtaining of motion III, however without affecting the representation of the cinematic diagram of principle of the machine.

Analyzing several constructive solutions, for one of the variants the authors have adopted a four-bar mechanism for the MT, and a cam gear mechanism with oscillatory pusher combined with a sine mechanism for MT_1 (in order to transform the oscillatory motion of a lever into the linear motion of the executing element E_1).

The detailed cinematic diagram of a sheet metal expanding machine with oscillatory main motion achieved as described above is presented in figures 5 and 6.

Easily identifiable are the electric motor 7, the belt transmission (8 and 10 are belt pulleys, and 9 are the belts), the flywheel 10, the clutch 11, brake 28, reduction gear (consisting of shafts 6 and 12, and gears 13 and 14). The shaft 6 is the main one, in continuous uniform rotation motion II. The transforming mechanism MT is of four-bar type,

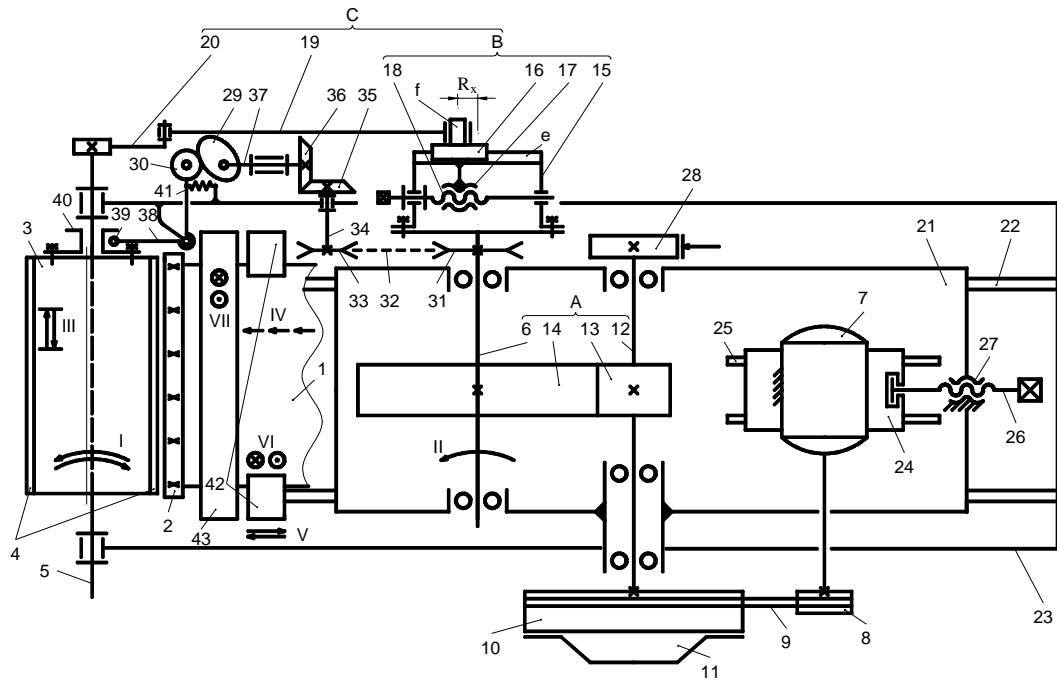

Figure 5. The kinematic diagram of a sheet metal expanding machine with oscillatory main motion (including shaft axes)

with articulated rods/bars, consisting of the eccentric part (of eccentricity R_x) fixed on and driven by the main shaft 6, rod 19 and oscillating rod 20. The base of the four-bar mechanism is the “distance” between the axis of the main shaft 6 and the axis of the fluted shaft 5. The executing element is cylinder 3 with interior fluting, actuated in oscillatory motion I by the fluted shaft 5. Two or more tools 4 are fixed on the cylinder at equal angles.

along which a slide 16 with a pin f can glide. The distance between the axis of the main shaft 6 and the axis of pin f is precisely the eccentricity R_x . The adjustment is made through a screw 18 – nut 17 mechanism. The screw 18 is radially and axially born in part 15, and nut 17 is fixed on slide 16. After completion of the adjustment, slide 16 is blocked.

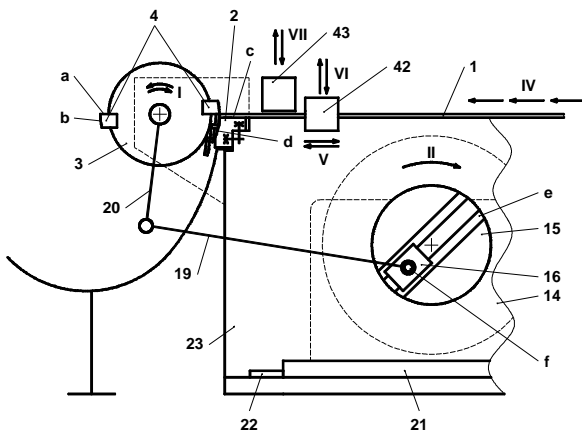

Figure 6. The kinematic diagram of a sheet metal expanding machine with oscillatory main motion (side „view”; detail)

The position of the oscillatory motion I can also be adjusted. For this purpose, the distance between the axis of the main shaft 6 and the axis of the fluted shaft 5 is modified through the gliding of slide 21 along guide 22, which slide bears the electric motor, the flywheel, the coupling, brakes, and reduction gear of the main linkage of the machine. After the adjustment, slide 22 is blocked in the new position. The motion III, of discrete alternating left right motion of cylinder 3, is ensured by the means of a linkage that takes over the motion of the main shaft 6.

The amplitude of the oscillatory motion I is set by adjusting the eccentricity R_x . For this purpose, a part 15 is fixed on the main shaft 6; on the front of part 15 a diameter guide e is practiced,

This consists of sprockets 31 and 33, chain 32, shaft 34, bevel gears 35 and 36, shaft 37, cam 29, pusher 30, lever 38 and shoe 39, that is placed in the channel of yoke 40 on which cylinder 3 is fixed. The chain transmission and/or the bevel gear group 35-36 also has the role of a reductor R_1 , the obtained ratio i_{R1} being 1:2. The rotation motion of cam 29 is transformed into the oscillatory motion of lever 38, and is then transformed into linear motion III by means of the sine mechanism that also includes the shoe 39. The helical traction

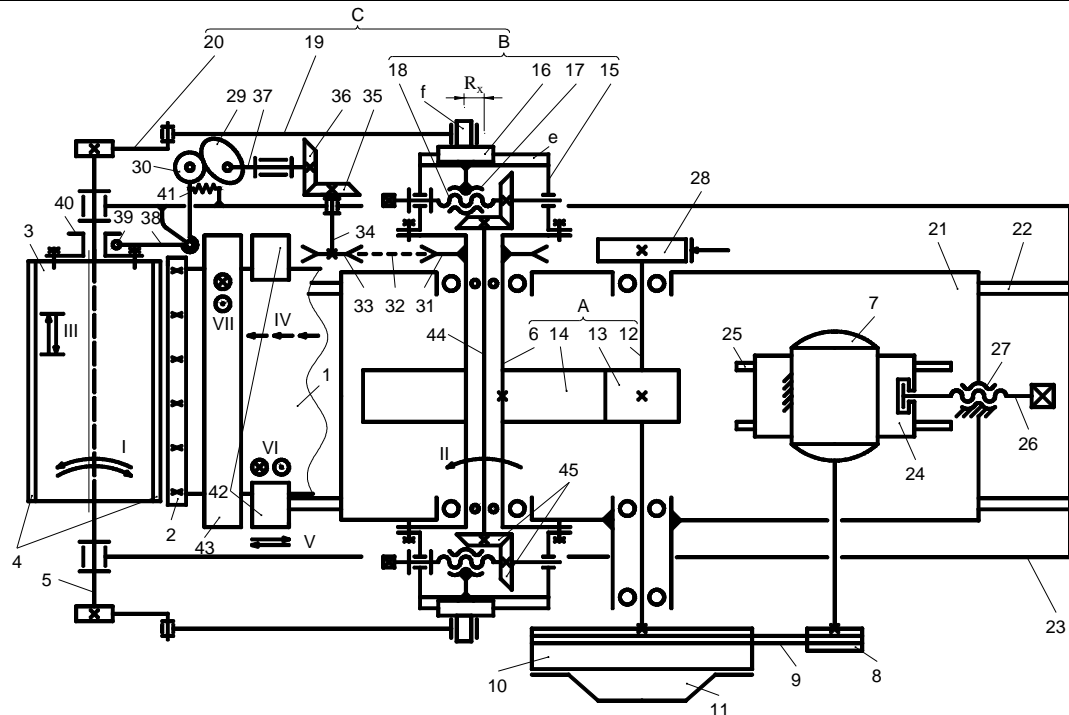

Figure 7. The cinematic diagram of a sheet metal expanding machine with oscillatory main movement
The variant with two identical four-bar mechanisms, in mirror position

spring 41 ensures the forced contact of the cam 29 – pusher 30 couple.

The motion IV of discrete feed of the semi-product sheet 1 is guaranteed by the feed devices 42. These carry out the motion V and VI. Clamping takes place prior to the feed of the sheet, and release after completion of the feed. The “feed” part of motion V is transmitted to the semi-product sheet 1 as motion IV.

Device 43 carries out motion VII, of clamping-release of the semi-product sheet. The release is prior to the feed of the sheet, and clamping after completion of the feed. During the effective stroke of the mobile tool, the semi-product sheet needs to be fixed.

Devices 42 and 43 correspond to the auxiliary systems SA₂₁, SA₂₂ and SA₃ from the cinematic diagram of principle of figure 4. Their type is not specified, this aspect not being essential for the construction and functioning of the machine.

The mobile tools 4 have the front (rake) surface **a** (see figure 6) profiled like a sliding block, the profile being the one to be transposed to the mesh of the expanded sheet metal through imprinting, a process that involves local denting and bending of the semi-product sheet. The clearance surface **b** of the mobile tools 4 is cylindrical, of radius R_{sm} , obtained by grinding. The (re)sharpening of the mobile tools 4 is always

made when these are fixed on cylinder 15, which must be easily clamped/declamped on/from the machine. It is recommended for the machine to have a spare cylinder.

The fixed tools 2, fixed by screws on machine frame 23, have a linear active edge, a plane front (rake) surface **c**, while the clearance surface **d** is cylindrical and concave, of radius $R_{sf} = R_{sm} + j$, j representing the clearance between the fixed and the mobile tool.

In order to balance the stress of the fluted shaft 5 and the decrease of the stress of the four-bar mechanism for the transformation of rotation II into oscillatory main motion I, a variant of the sheet metal expanding machine was developed, characterized by the presence of two identical four-bar mechanisms, figure 7.

While practically no cinematic adjustments are required, some interesting constructive modifications are imposed, determined by the requirement of identical and synchronous adjustment of the eccentricity R_x of the two four-bar mechanisms. Screw 18 in rotation must implicitly determine the driving of the other one too, hence a rigid cinematic link and a 1 to 1 transmission ratio is required between driving a them. This demand was met by inserting bevel gears 45 and, inside main shaft 6, which becomes tubular, of a shaft 44 that ensures the rigid cinematic link between the two bevel gears 45. The

adjustment of eccentricity R_x is identically possible from both lateral sides of the machine.

Constructive solutions for some of the machine components, modelled in Catia, are presented in figures 8, 9 and 10.

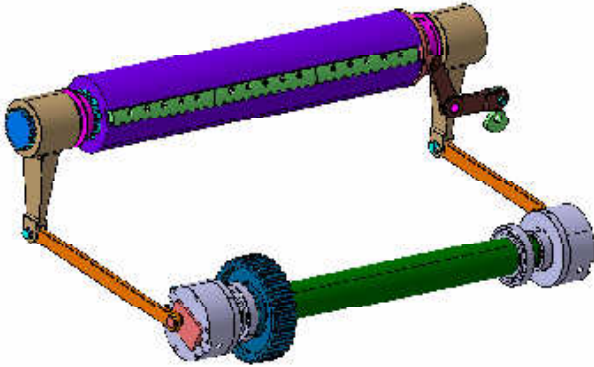

Figure 8. The transforming mechanism for generating the main motion

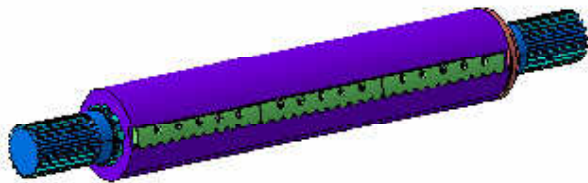

Figure 9. The cylinder with two cutters

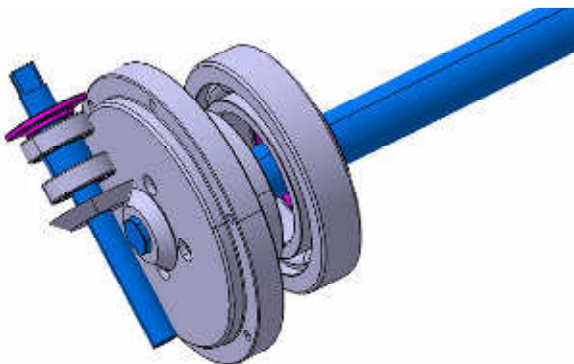

Figure 10. Parts of the system for adjusting the amplitude of the oscillatory motion

5. Conclusions

Worldwide evolution shows the continuous growth of the weight held by industrial production achieved by various cold forming methods. Expanded sheet-metals also follow this tendency. These are used as finite parts, but especially as semi-products.

The few sheet-metal expanding machine manufacturers promote modernizations, improvements or new constructive solutions to a certain degree, which however do not include changes of the working principle.

The cinematic diagram of principle of a machine-tool [1], in particular of a sheet metal expanding machine, allows the highlighting of some mechanisms and structure elements whose replacement or constructive optimization represents a major innovative approach. It is to be noticed that identical cinematic diagrams of principle can correspond to certain different cinematic solutions for the same type of machine, or even for different types of machines.

In machine building, frequently the rotation motion, and in particular the oscillatory one, is easier to obtain and more favourable than the translation motion. It is preferable, every time possible, for the work process to be conceived so that the main motion and most of the other auxiliary motions to be rotation or oscillatory motions.

The paper proves the possibility of redesigning a sheet-metal expanding machine by replacing the linear alternating main motion by a self-returning oscillation, and by carrying out the corresponding required constructive modifications. While the cinematic complexity of the machine remains unchanged, the constructive and technological benefits are evident: reduced size and mass for the machine, the simplicity of adjustments, simplicity in changing and sharpening the mobile tool, superior dynamic characteristics.

References

1. Botez, E.: *Machine-Tools (Maşini-Unelte)*. Vol. I, The Theory (Teoria), "Tehnică" Publishing House, Bucureşti, 1977, Romania (in Romanian)
2. Cioară, R., Cioară, S., Cioară, Rx: *Process, tool and machine for sheet metal expanding (Procedeu, sculă și mașină de expandat tablă)*. Patent RO no. 112094 C, Int.Cl. B 21 D 28/36; B 21 D 47/02, 1998. Available on <http://v3.espacenet.com/origdoc?DB=EPODOC&IDX=RO112094&F=0&QPN=RO112094>
3. Cioară, Ruxandra, Cioară, R., Mărăscu-Klein, Vl.: *Hydraulic Actuated Automatic Sheet-Metal Expanding Machine*. Annals of MTeM for 2001 & Proceedings of 5th International MTeM Symposium, p. 127-130, ISBN 973-85354-1-7, Technical University of Cluj-Napoca, Romania, 4th-6th October 2001, Alma Mater Publishing House, Cluj-Napoca, Romania
4. Stănciulescu, T., Belous, V., Moraru, I.: *Creation Science Treatise (Tratat de creatologie)*. "Performantica" Publishing House, ISBN 973-97813-8-1, Iasi, Romania, 1998 (in Romanian)
5. Tabără, V., Tureac, I.: *Machines for Cold Forming (Maşini pentru prelucrări prin deformare)*. "Didactică și Pedagogică" Publishing House, Bucureşti, 1984, Romania (in Romanian)
6. * * *: <http://www.globalspec.com>. Accessed in 2007-06-15