

## ESTABLISHING PARAMETERS THAT INFLUENCE THE LENGTH AND SHAPE OF THE ABRASIVE GRAIN PATH AT TRAVERSE SUPERFINISHING

Badea LEPĂDĂTESCU, Adela-Eliza DUMITRAŞCU, Ioan ENESCU

“Transilvania” University of Braşov, Romania

**Abstract.** The paper presents the parameters that influence the length and shape of the abrasive grain path at traverse superfinishing. Starting technological parameters of the superfinishing process are mathematical modelled the equations which show the trajectory of the abrasive grain on the workpiece surface during the superfinishing machining for two types of the reciprocating motions of the tool system: one with low frequency for roughing and other with high frequency for finishing. The final equations of the grain trajectory are dependent of the machining parameters and constructive characteristics of abrasive tool.

Keywords: surface finish, production rate, parameter, attachments

### 1. Introduction

The process of superfinishing, as it's also known, is finding wider application in metalworking. Demands for better performance in rotating components coupled with tighter manufacturing tolerances is leading shops to look at superfinishing as a final process step to achieve low and sub-micron finishes on ground parts.

Grinding, even with fine abrasive grit, leaves what are essentially machining marks on the surface of the workpiece. These marks take the form of peaks and valleys that are very small and generally require a microscope to see. However, they can affect how well the part performs [1].

Superfinishing removes the peaks on the workpiece leaving a more stable microsurface. Different abrasive pattern, grits and oscillation rates enable the shop to impart cross hatch patterns for lubrication retention and other patterns, as specifications require. Workpieces including transmission shafts, axles, bearing races and other wear applications will usually see an extended life cycle from the use of superfinishing [4, 5].

Finding the equations of the abrasive grain path is important for the shape of cross hatch pattern leaves by the tool on the workpiece surface.

First, it is establish the length of the abrasive grain path at traverse superfinishing according with some process parameters.

### 2. Factors that influence the abrasive grain path on the workpiece surface

During the process of superfinishing in many cases the length of the workpieces is bigger than those of the abrasive stone. For this reason the abrasive stone must add a movement of feeding along the workpiece axis with the speed  $v_0$  to cover the entire length of the part surface. This movement is achieved by the feed mechanism of the lathe where the superfinish attachment is placed (figure 1).

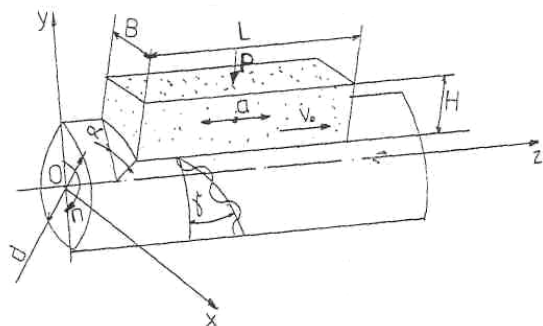

Figure 1. The movements of the abrasive stone and the part during superfinishing

In figure 1, abrasive stone dimensions are  $L$ ,  $B$ ,  $H$ ,  $a$  is the amplitude of reciprocating movement,  $v_0$  is the axial feed of abrasive stone [m/min], and the rotation speed of the workpiece is  $n$  [rpm].

Referring to figure 2, the radius OM of a point M of tool has the values on the three axes given by the equations [2]:

$$\begin{cases} X = R \cdot \sin \theta \\ Y = R \cdot \cos \theta \\ Z = v_0 \cdot \tau \end{cases} \quad (1)$$

where  $R$  is the workpiece radius,  $\theta$  is the angle turned through by OM in time  $t$ ,

$$\theta = \omega \cdot t \quad (1)$$

where  $\omega$  being the angular velocity.

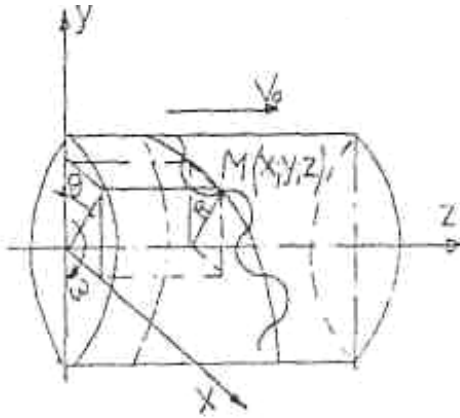

Figure 2. The motion of a point M of tool on the workpiece surface

Taking into account equation (2), relations (1) become:

$$\begin{cases} X = R \cdot \sin(\omega t) \\ Y = R \cdot \cos(\omega t) \\ Z = v_0 \cdot \tau \end{cases} \quad (3)$$

The velocity of the point M is given by the equation:

$$V = \sqrt{v_x^2 + v_z^2 + v_y^2} \quad (4)$$

The components of the velocity of point M are:

$$\begin{cases} V_x = \omega \cdot R \cdot \cos \theta \\ V_y = -\omega \cdot R \cdot \sin \theta \\ V_z = v_0 \end{cases} \quad (5)$$

In figure 3 is shown abrasive grit path on the workpiece surface in the coordinate system Ouz [3].

Starting from the formula:

$$\begin{cases} \theta = \frac{u}{R} \\ \frac{1}{R} = k_1 \end{cases} \quad (6)$$

the equations (3) become:

$$\begin{cases} X = R \cdot \sin(k_1 \cdot u) \\ Y = R \cdot \cos(k_1 \cdot u) \\ Z = k \cdot u \end{cases} \quad (7)$$

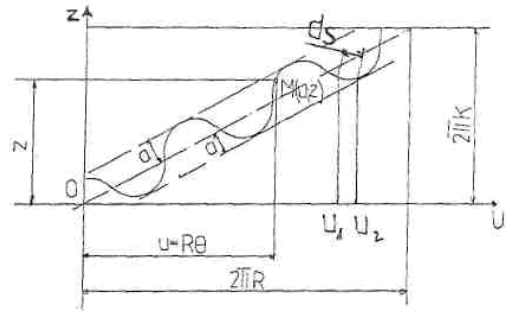

Figure 3. The abrasive grit path on the workpiece surface

The components of the speed of point M will be:

$$\begin{cases} V_x = \omega \cdot R \cdot \cos(k_1 \cdot u) \\ V_y = -\omega \cdot R \cdot \sin(k_1 \cdot u) \\ V_z = v_0 \end{cases} \quad (8)$$

At one rotation of workpiece the time is:

$$\tau = \frac{\theta}{\omega} = \frac{2\pi}{\omega} \quad (9)$$

and the displacement of an abrasive grit on the axis Oz during one rotation of workpiece is:

$$s = v_0 \cdot \tau = v_0 \cdot \frac{2\pi}{\omega} = 2\pi \cdot k \quad (10)$$

where  $k = \frac{v_0}{\omega}$ .

The inclination angle of the abrasive grit path is given by the equation:

$$\operatorname{tg} \gamma = \frac{v_0}{v_t} \quad (11)$$

and

$$v_t = \omega \cdot R \quad (12)$$

being the tangential speed of the point M.

The length of an elementary arch  $ds$  (figure 3) is given by the formula:

$$ds = du \cdot \sqrt{1 + \left(\frac{dz}{du}\right)^2} \quad (13)$$

In the coordinate system Ouz the point M has the coordinate:

$$z = a \cdot \sin(k_1 \cdot u) + v_0 \cdot \tau \quad (14)$$

and

$$\frac{dz}{du} = a \cdot R \cdot \cos(k_1 \cdot u) + \frac{v_0}{\omega} \quad (15)$$

Taking into account equation (13) and (15), the displacement of abrasive grit between  $u_1$  and  $u_2$  will be:

$$S = \int_{u_1}^{u_2} \sqrt{1 + \left[ a \cdot R \cdot \cos(k_1 \cdot u) + \frac{v_0}{\omega} \right]^2} du \quad (16)$$

At one rotation of the workpiece the limits of integration will be 0 and  $2\pi$ , and the length of the abrasive grain path will be:

$$S = \int_0^{2\pi} \sqrt{1 + \left[ a \cdot R \cdot \cos(k_1 \cdot u) + \frac{v_0}{\omega} \right]^2} du \quad (17)$$

From the equation (17) it can be seen that the length of the abrasive grit path is proportional with the amplitude of oscillation  $a$  and with the axial speed  $v_0$  of the abrasive stone. Increasing these values the length of path on the workpiece surface will be bigger and the surface finish will be better. But these values have their limitations according with the reasons regarding the evacuations of chips and the heat generate during the process. The recommended values are from amplitude  $a = 1 \div 3$  mm, and from axial speed  $v_0 = 30 \div 40$  m/min.

### 3. The superfinishing process with two reciprocating motions of the same amplitude and different frequency

The schematic illustration of the mechanism that generates the movements of tool and workpieces is shown in figure 4.

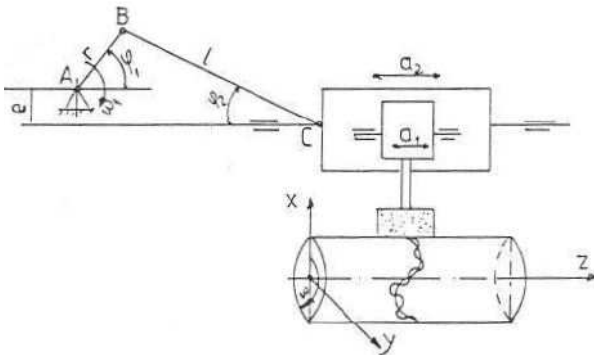

Figure 4. Schematic illustration of the superfinishing with two reciprocating motions

The workpiece has a rotational motion with angular velocity  $\omega$  and abrasive stone has two motions, one with the amplitude of oscillations  $a_1$  and other with the amplitude  $a_2$ . These motions are generated mechanically ( $a_1$ ) and pneumatically ( $a_2$ ). The resulting motion will have a motion of composing these two motions. To increase the

cutting capacity the workpiece has also the feed motion with the value  $v_0$ .

In figure 5 the radius OM of a tool point is decomposed on the axes by the equations:

$$\begin{cases} x = R \cdot \sin \theta \\ y = R \cdot \cos \theta \\ z = v_0 \cdot \tau + s \end{cases} \quad (18)$$

where

$$s = r \cdot \cos \phi_1 + l \cdot \sqrt{1 - (\lambda \cdot \sin \phi_1 + k)^2} \quad (19)$$

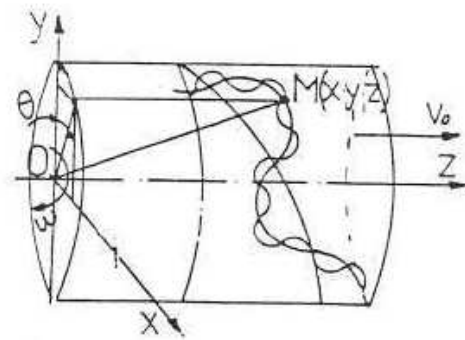

Figure 5. The motion of an abrasive grit on the workpiece surface

With the equations:

$$\begin{cases} \phi_1 = \omega_1 \cdot \tau \\ \theta = \omega \cdot \tau \end{cases} \quad (20)$$

the equations (18) becomes:

$$\begin{cases} x = R \cdot \sin(\omega \cdot \tau) \\ y = R \cdot \cos(\omega \cdot \tau) \\ z = v_0 \cdot \tau + r \cos(\omega_1 \tau) + l \sqrt{1 - [\lambda \sin(\omega_1 \tau) + k]^2} \end{cases} \quad (21)$$

The velocity of the point M are given by the equations:

$$\begin{cases} V_x = \frac{dx}{d\tau} = \omega R \cos(\omega \tau) \\ V_y = \frac{dy}{d\tau} = -\omega R \sin(\omega \tau) \\ V_z = \frac{dz}{d\tau} = v_0 - R \omega_1 \sin(\omega_1 \tau) - \frac{\lambda \omega_1 \cos(\omega_1 \tau) [\lambda \sin(\omega_1 \tau) + k]}{\sqrt{1 - [\lambda \sin(\omega_1 \tau) + k]^2}} \end{cases} \quad (22)$$

The module of velocity is given by the equation:

$$V = \sqrt{V_x^2 + V_y^2 + V_z^2} \quad (23)$$

If is taking into account the equations:

$$\begin{cases} \tau = \omega_1 \tau = \omega_1 \frac{\theta}{\omega} \\ k_1 = \frac{\omega_1}{\omega} \\ k_2 = \frac{v_0}{\omega} \end{cases} \quad (24)$$

the equations (24) becomes:

$$\begin{cases} x = R \cdot \sin \theta \\ y = R \cdot \cos \theta \\ z = k_2 \theta + r \cos(k_1 \theta) + l \sqrt{1 - [\lambda \sin(k_1 \tau) + k]^2} \end{cases} \quad (25)$$

The length of the arch between  $u_1$  and  $u_2$  has the value:

$$S = \int_{u_1}^{u_2} du \sqrt{1 + \frac{v_0}{\omega R} - k_4 \sin(k_4 u) r - \frac{u_2}{u_1} \sqrt{l \frac{[\lambda \sin(k_4 u) + k] k_4 \lambda \cos(k_4 u)}{\sqrt{1 - [\lambda \sin(k_4 u) + k]^2}}} } \quad (26)$$

where  $k_4 = \frac{\omega_1}{\omega R}$ .

To find the length of the abrasive grain path is taking the limit of integration 0 and  $2\pi R$ .

#### 4. Conclusions

Knowing the length of the abrasive grit path on the workpiece surface during superfinishing process will be easier to obtain the roughness surface according with the requirements of the design. Choosing the proper values of the process parameter during superfinishing the time per operation will be optimized.

#### References

1. Lepădătescu, B.: *Study regarding the superfinishing process*. PhD thesis, "Transilvania" University of Brasov, Braşov, Romania, 1998 (in Romanian)
2. Avalone, E., Baumaester, T.: *Marks' standard handbook for mechanical engineering*. McGraw-Hill, 2001, ISBN 0071428674.
3. Koepfer, C.: *When need really accurate bores*. MMS Online, 2006
4. Lepădătescu, B., Simon, A.E., Mareş, G.: *Surface technology*. "Transilvania" University Press, ISBN 973-635-390-7, Braşov, Romania, 2005 (in Romanian)
5. Lepădătescu, B., Simon, E.A.: *Vehicles manufacturing*. "Transilvania" University Press, ISBN 973-635-615-9. 2006 (in Romanian)