

PROBLEMS ABOUT TOLERANCES AT THE KINEMATICS GENERATION OF POLYHEDRAL SECTIONS BASED ON THE HYPOCYCLOIDS

Cristina Ileana PASCU, Iulian POPESCU

University of Craiova, Romania

Abstract. For this study it has started from generation principle of polygons on the basis of cyclic curves. This research presents tolerances and processing accuracy by turning of some surfaces with polyhedral sections. Hypocycloids are generated that on the middle zone approximate straight lines belong to polyhedral sections. Analogous, the precision at a square generation has been studied establishing that the deviations are bigger than at the hexangle generation. Examples for obtained curves are presented and the deviations given theoretical section are evaluated. Thus, the processing of pieces with polyhedral sections is very productive and the resulted accuracy is into tolerated heights limits.

Keywords: hypocycloid, upper deviation, tolerance, polyhedral turning

1. Introduction

The method for obtaining surfaces with polyhedral sections by turning is acquainted [1, 2, 3]. For this purpose cycloid curves generated by additional motions are used and thus, these processing's achieve in the same time with other phases. Thus, the final output increase.

Further on, the curves like hypocycloid are analysed.

2. Hypocycloid generation

If a movable circle with r_2 radius rolls without gliding into a fixed circle with r_1 radius, like in figure 1, then a point M belongs to package circle plots on basis plan (namely fixed circle) a normal hypocycloid.

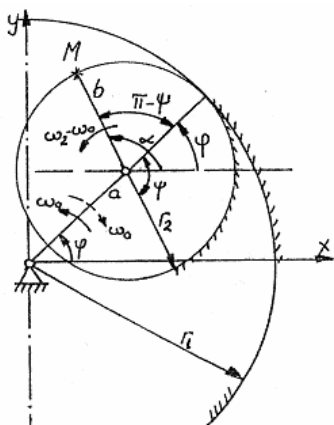

Figure 1. Hypocycloid generation

In M point is mounted a turning tool and on great circle axis the piece axis is positioned. By reversing, that means by a movement generation for all elements, equal and inverse direction with “a” bracket motion and the incentres of both gear wheels will become fixed and will have rotary motions.

Having:

$$r_1 \cdot \varphi = r_2 \cdot \psi, \quad (1)$$

$$a = r_1 - r_2 \quad (2)$$

result:

$$\alpha = \pi + \left(1 - \frac{r_1}{r_2}\right)\varphi \quad (3)$$

For “s” size of jaw is obtained:

$$b = r_1 - \frac{s}{2} \quad (4)$$

The M point coordinates are:

$$x = a \cos \varphi + b \cos \alpha \quad (5)$$

$$y = a \sin \varphi + b \sin \alpha$$

Swedish's E. Dalgren and D. Svinson are established the relationship:

$$n_p \cdot L = n_s \cdot c. \quad (6)$$

where: n_p is piece speed; L is number of polygon sides; n_s is tool speed of revolutions and c is cutting tools number.

3. Chip removing process of a piece with polyhedral section

A hexangle is achieved by generation of two hypocycloids with two cutting tools staggered at 90° , figure 2, for two rotations of cutting tools.

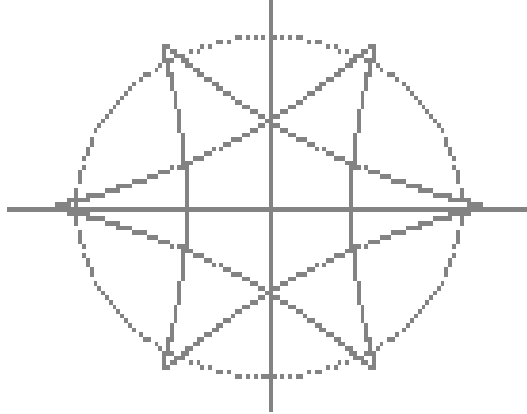

Figure 2. Hexangle generation by using two cutting tools

It can be noticed that the hexangle sides are curvilinear. First cutting tool generated hypocycloid from figure 3 and the second the hypocycloid presented in figure 4.

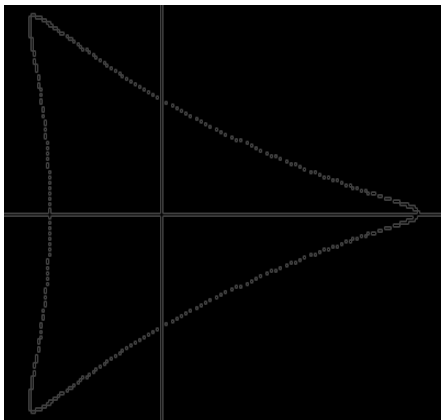

Figure 3. Hypocycloid generated by first cutting tool

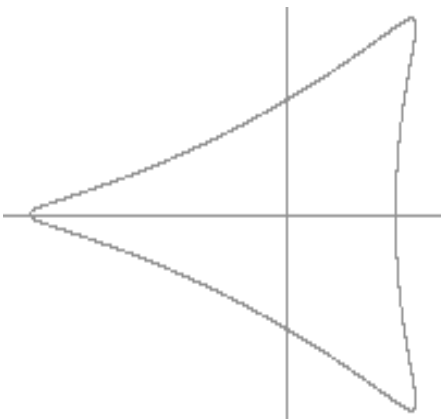

Figure 4. Hypocycloid generated by second cutting tool

For accuracy processing study that means an evaluation of discrepancies between generated lines of curvature and straight lines (theoretical), a machine routine had been compiled that these deviations were calculated.

Followings concrete data have been used: size of jaw $s = 14$ mm; number gear teeth $z_1 = 42$ teeth; number gear teeth $z_2 = 28$ teeth; modulus $m = 1$ mm (pitch line of a gear have been used in accordance with figure 1), $L = 6$; $c = 2$; $d = 4,04153$; $r_6 = 8,082904$. Only deviations for PR zone from figure 5 have been evaluated because these deviations are the same on following sides.

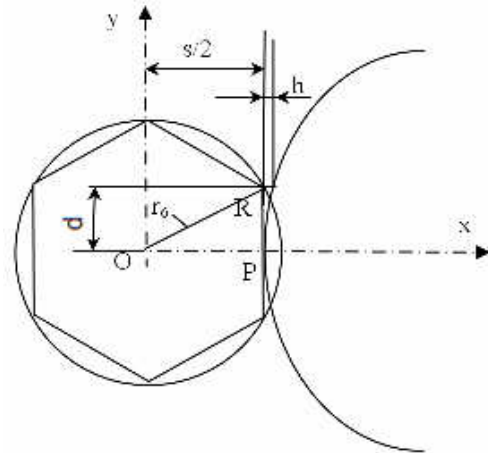

Figure 5. Basic diagram for hexangle side calculus

The values obtained for “d” zone are shown in table 1.

Table 1. The calculated values.

φ	x_1	y_1	h
523.4135	7.144884	4.017628	.1448841
523.6136	7.141453	3.970019	.1414528
523.8136	7.138062	3.922379	.1380615
524.0136	7.134711	3.874696	.1347103
524.2136	7.131398	3.826998	.1313977
524.4136	7.128124	3.779257	.1281242
524.6136	7.124892	3.731501	.1248918
524.8136	7.121699	3.683704	.1216984
525.0136	7.118547	3.635891	.118547
525.2136	7.115435	3.588037	.1154347
525.4136	7.112363	3.54017	.1123629
525.6136	7.10933	3.492275	.1093302
525.8137	7.10634	3.444341	.1063399
526.0137	7.103388	3.396394	.1033874
526.2137	7.100477	3.348408	.1004763
526.4137	7.097607	3.30041	9.760714E-02
526.6137	7.094778	3.252373	9.477758E-02
526.8138	7.091988	3.204325	9.198761E-02
527.0138	7.089239	3.156239	8.923864E-02
527.2138	7.086533	3.108143	8.653259E-02
527.4138	7.083865	3.060022	8.386517E-02
527.6138	7.081241	3.011866	8.124066E-02

527.8138	7.078655	2.963699	7.865429E-02
528.0138	7.076111	2.915497	7.611084E-02
528.2138	7.073609	2.867287	.0736084
528.4138	7.071144	2.819041	7.114411E-02
528.6138	7.068725	2.770786	6.872463E-02
528.8138	7.066344	2.722498	6.634378E-02
529.0139	7.064006	2.674202	6.400538E-02
529.2139	7.061711	2.625885	6.171036E-02
529.4139	7.059452	2.577536	5.945206E-02
529.6139	7.05724	2.52918	5.723953E-02
529.8139	7.055066	2.480791	5.506611E-02
530.014	7.052934	2.432397	5.293417E-02
530.214	7.050843	2.383972	5.084324E-02
530.414	7.048795	2.335541	4.879523E-02
530.614	7.046788	2.287079	4.678774E-02
530.814	7.044823	2.238613	.0448227
531.014	7.042899	2.190131	4.289913E-02
531.214	7.041016	2.141618	4.101563E-02
531.414	7.039179	2.093102	3.917837E-02
531.614	7.03738	2.044557	3.737927E-02
531.814	7.035624	1.99601	3.562403E-02
532.0141	7.033909	1.947434	3.390837E-02
532.2141	7.032237	1.898856	3.223705E-02
532.4141	7.030606	1.850251	3.060579E-02
532.6141	7.029018	1.801645	2.901745E-02
532.8141	7.027471	1.753026	2.747059E-02
533.0141	7.025965	1.70438	2.596522E-02
533.2141	7.024503	1.655734	2.450276E-02
533.4141	7.023083	1.607062	2.308321E-02
533.6141	7.021705	1.558391	2.170515E-02
533.8141	7.02037	1.509695	2.036953E-02
534.0142	7.019077	1.461001	1.907635E-02
534.2142	7.017823	1.412283	1.782322E-02
534.4142	7.016616	1.363567	1.661539E-02
534.6142	7.01545	1.31484	1.544952E-02
534.8142	7.014323	1.266091	1.432324E-02
535.0143	7.013242	1.217345	1.324177E-02
535.2143	7.012202	1.168576	1.220131E-02
535.4143	7.011204	1.119812	1.120377E-02
535.6143	7.010249	1.071026	1.024914E-02
535.8143	7.009337	1.022245	9.336948E-03
536.0143	7.008466	.9734431	8.465767E-03
536.2143	7.007639	.9246471	7.638932E-03
536.4143	7.006854	.875844	6.854058E-03
536.6143	7.00611	.8270209	6.110192E-03
536.8143	7.00541	.7782049	5.410195E-03
537.0143	7.004754	.7293696	4.75359E-03
537.2144	7.004138	.6805421	4.137993E-03
537.4144	7.003566	.631696	3.565312E-03
537.6144	7.003035	.5828585	3.035069E-03
537.8144	7.002549	.5340031	2.549172E-03
538.0144	7.002104	.4851572	2.103806E-03
538.2145	7.001702	.4363075	1.701355E-03
538.4145	7.001343	.3874411	1.342297E-03
538.6145	7.001024	.3385851	1.024246E-03
538.8145	7.00075	.2897132	7.49588E-04
539.0145	7.000519	.2408524	5.187989E-04
539.2145	7.000329	.1919898	3.290177E-04
539.4145	7.000184	.1431124	1.835823E-04

539.6145	7.000078	9.424721E-02	7.82013E-05
539.8145	7.000019	4.536798E-02	1.859665E-05

In diagrams from figure 6 the values from table 1 are presented. It can be noticed that variations of indicating point (from second cutting tool) and “h” deviation with rotation angle of gear wheel with “r₁” radius are determined.

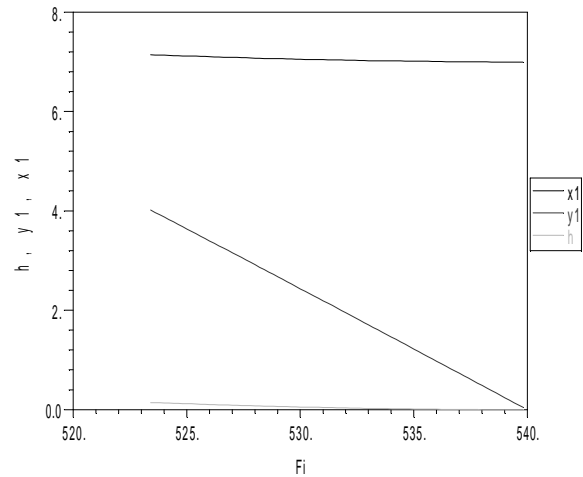

Figure 6. The deviations for PR zone

The fluctuation of deviations “h” is detailed observed in diagram from figure 7 that a different curve from a line is obtained therefore the deviation varies non-linear.

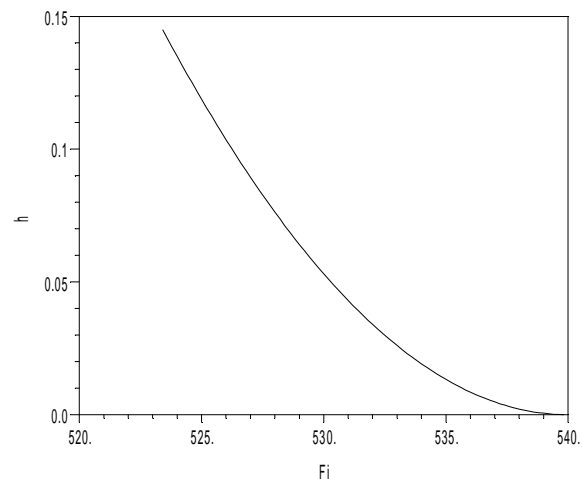

Figure 7. The variations of deviation “h”

From diagram 7 and table 1, it can be noticed that the upper deviation appears in R point (figure 5) and have value of 144 μm.

On the basis of SR EN 20286-1 of 1997 it establishes that the upper deviation from table 1 approximately complies with fundamental

tolerance with IT12 precision, at h12 for arbors or H12 for bores tolerance field position, SR EN 20286-2 of 1997.

In figure 8 the hypocycloid plotted by a cutting tool and the section of hypocycloid plotted of the other cutting tool on PR zone is presented.

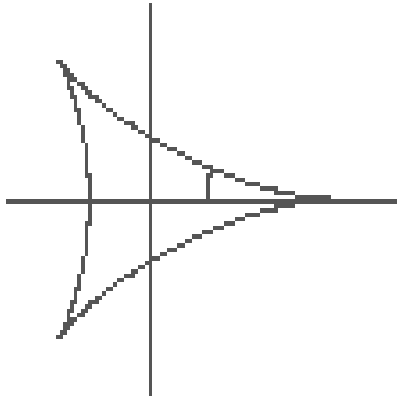

Figure 8. Hypocycloid plotted by two different cutting tools

4. Chip removing process of a piece with square section

Sections with 4 sides can be generated by modification of gear reduction rate and cutting tools positions. Thus, in figure 9 can be observed a rhomb plotting ($z_1 = 80$ teeth; $z_2 = 40$ teeth; $s = 14$ mm, two cutting tools at 180°).

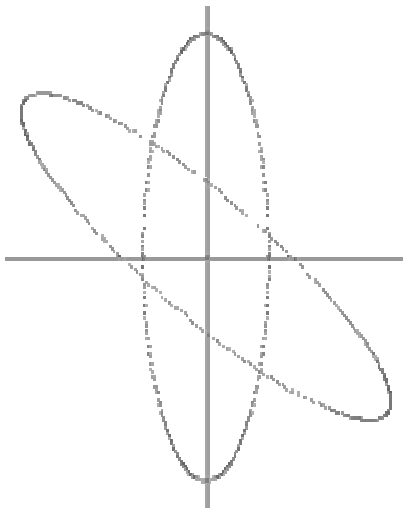

Figure 9. A rhomb plotting by two cutting tools

It can be noticed that hypocycloids became ellipses. Thus, changing the gearing at $z_1 = 60$ teeth, $z_2 = 30$ teeth, a square generated by two ellipses is obtained.

For deviations account the notations from figure 11 are used; here, the ultimate deviations are on middle side.

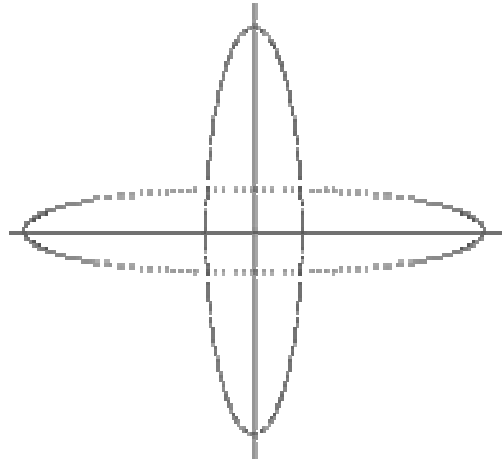

Figure 10. A square generated by two ellipses

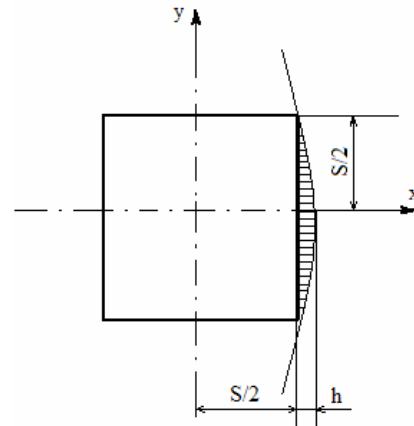

Figure 11. Deviation

The values are presented in table 2 and figure 12.

Table 12. The calculated values

φ	x	y	h
169.3986	7.863453	6.991117	.8634529
169.5986	7.868544	6.860693	.8685436
169.7986	7.873538	6.730194	.873538
169.9986	7.878436	6.599604	.8784361
170.1986	7.883238	6.468934	.8832378
170.3986	7.887944	6.338194	.8879432
170.5985	7.892553	6.207368	.8925524
170.7985	7.897065	6.076466	.8970652
170.9985	7.901481	5.945499	.9014807
171.1985	7.905804	5.81445	.9058037
171.3985	7.910026	5.683331	.9100256
171.5985	7.914153	5.552151	.9141531
171.7985	7.918186	5.420895	.9181862
171.9985	7.922121	5.289582	.9221211
172.1985	7.925961	5.158195	.9259606
172.3985	7.929705	5.026746	.9297047
172.5985	7.933351	4.895244	.9333506
172.7985	7.936898	4.763674	.9368972
172.9985	7.940348	4.632045	.9403477
173.1985	7.943703	4.500369	.9437027
173.3985	7.946965	4.36863	.9469652

173.5985	7.950125	4.236837	.9501248
173.7985	7.953187	4.105001	.953187
173.9985	7.956161	3.973106	.9561606
174.1985	7.959029	3.841172	.9590292
174.3985	7.961802	3.709182	.9618015
174.5985	7.96448	3.577148	.9644794
174.7985	7.967058	3.445078	.9670582
174.9985	7.969544	3.312957	.9695434
175.1985	7.97193	3.180796	.9719296
175.3985	7.974216	3.048606	.9742155
175.5985	7.976409	2.916369	.9764089
175.7985	7.978505	2.784097	.9785051
175.9985	7.9805	2.651799	.9805002
176.1985	7.9824	2.519461	.9823999
176.3985	7.984205	2.387091	.9842043
176.5985	7.985913	2.254702	.9859123
176.7985	7.987517	2.122276	.9875164
176.9984	7.989029	1.989825	.9890289
177.1984	7.99044	1.857358	.9904394
177.3984	7.991758	1.724859	.9917574
177.5984	7.992975	1.592339	.9929752
177.7984	7.994099	1.459809	.9940987
177.9984	7.995119	1.327253	.9951191
178.1984	7.996046	1.19468	.9960461
178.3984	7.996878	1.062101	.9968777
178.5984	7.997607	.9295007	.9976072
178.7984	7.99824	.796889	.9982395
178.9984	7.998778	.6642765	.9987774
179.1984	7.999216	.531647	.9992161
179.3984	7.99956	.3990199	.9995594
179.5984	7.999804	.266379	.9998036
179.7984	7.999954	.1337348	.9999532
179.9984	8	1.0987E-03	1

From diagram presented in figure 12 it can be observed that “h” deviation has maximum value for y minimum (on abscissa).

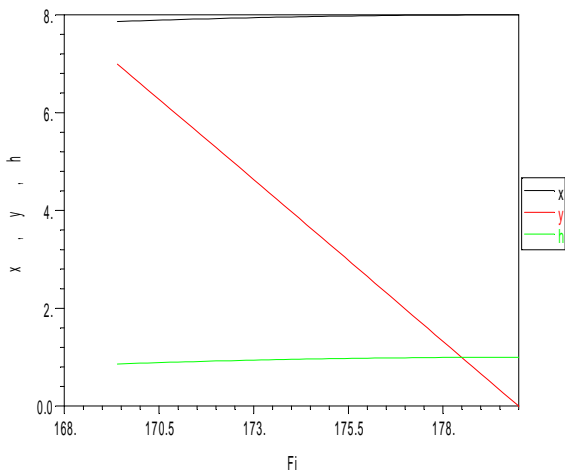

Figure 12. The variations of deviation “h”

In diagram presented in figure 13 the non-linear variation of “h” deviation is observed.

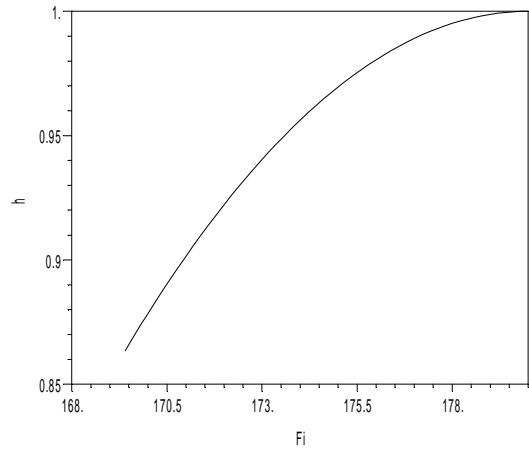

Figure 13. The non-linear variation of “h” deviation

Also, from diagram 13 and values from table 2 it establishes that the ultimate deviation is 1 mm. On the basis of SR EN 20286-1 of 1997 it establishes that the upper deviation from table 2 approximately complies with fundamental tolerance with IT14 precision, at h14 position for arbors or H14 for bores tolerances field position, SR EN 20286-2 of 1997. In figure 14 a general ellipse generated by a cutting tool and zone of interest of the second ellipse are shown.

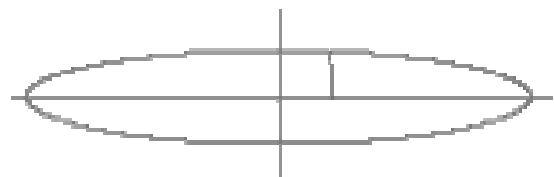

Figure 14. An ellipse generated by one cutting tool

6. Other Specifications

Similarly can be studied other types of polyhedral sections.

Thus, it can be obtained polygons with different number of sides (l) using a number of cutting tools (c) for an gear reduction rate (i) and modulus (m); thus hypocycloids can be standards, shorted or elongated, like in figures 15, 16 and 17.

When $i = 0,5$, hypocycloid becomes a straight line, like in figure 18, and thus obtaining a curvilinear path generation for a gear pair.

But, at processing accuracy an important role has feed motion, too. The hypocycloids present ahead into a single plan are considered. In fact, because of feed motion, the generation curves become spatially. This, in accordance with figure 19, there is rate of cutting \overline{v} , tangent on hypocycloid, feed rate \overline{v}_f , lengthways of direction of feed motion and the resultant velocity, \overline{v}_e ,

angle of direction of feed motion, φ and angle of cutting direction, η . Thus, on the processed surfaces contact points of tool on direction of resultant velocity appear.

$$l= 8 \quad c= 6 \quad i= .75 \quad z1= 50 \quad m= 2$$

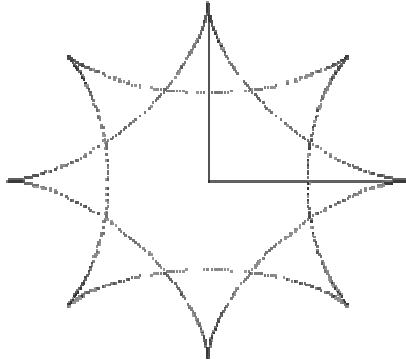

Figure 15. Normal hypocycloids ($b = r_2$)

$$l= 8 \quad c= 6 \quad i= .75 \quad z1= 50 \quad m= 1$$

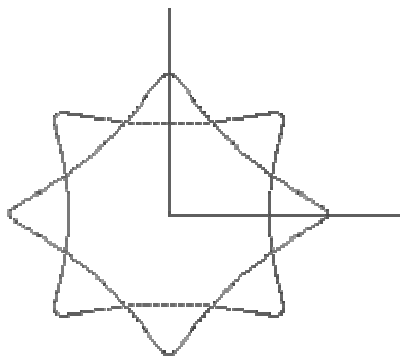

Figure 16. Elongated hypocycloids ($b = 1.5 \cdot r_2$)

$$l= 8 \quad c= 6 \quad i= .75 \quad z1= 50 \quad m= 3$$

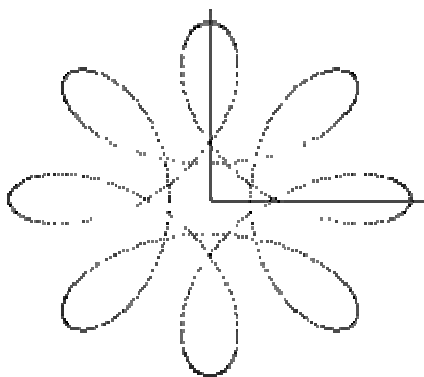

Figure 17. Shorted hypocycloids ($b = 0.5 \cdot r_2$)

$$l= 2 \quad c= 1 \quad i= .5 \quad z1= 50 \quad m= 2$$

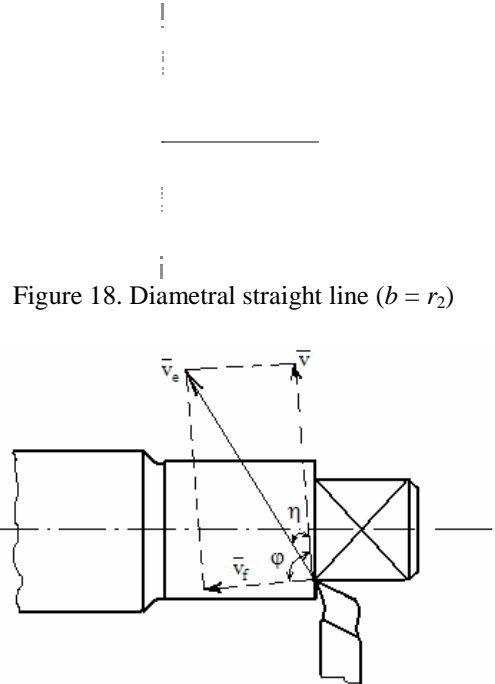

Figure 18. Diametral straight line ($b = r_2$)

Figure 19. The spatial movement. The cutting speed, \bar{v} and its components

6. Conclusions

- The method presented in this research allows generation of polyhedral section by rotary motions.
- The manners for generating of hexangles, rhombus and squares have been indicated.
- For squares and rhombus the hypocycloids change over into ellipses.
- The accuracy is better at hexangles generation than squares generation.

References

- Maroş, D.: *Mechanisms*. Printing House of Polytechnic Institute Cluj-Napoca, 1980 (in Romanian)
- Poluianov, V.T.: *Technological modernization of metal cutting devices*. Moskva, Sberdlovsk, 1975 (in Russian)
- Popescu, I.: *Mechanisms. New algorithms and programming*. "Universitaria" Publishing House, Craiova, 1999 (in Romanian)
- Popescu, I.: *Uncircular section surface generation using cycloids (I)*. Proc.of "Tehnologii, Calitate, Maşini, Materiale" CNMU '96, no. 21, "Tehnică" Publishing House, Bucharest, p. 116-121,1996 (in Romanian)
- Popescu I.: *Uncircular section surface generation using cycloids (II)*. Proc.of "Tehnologii, Calitate, Maşini, Materiale" CNMU '96, no. 21, "Tehnică" Publishing House, Bucharest, p. 122-127,1996 (in Romanian)
- ***: SR EN 20286-1/1997 ISO Tolerance System. Part 1.
- ***: SR EN 20286-2/1997 ISO Tolerance System. Part 2. Tables for tolerance and ultimate deviations.